

## StormFilter Configuration Guide



# The Stormwater Management StormFilter®

The Stormwater Management StormFilter® (StormFilter) is a passive, flow-through, stormwater filtration system. The system is comprised of one or more structures that house rechargeable, media-filled cartridges which trap particulates and adsorb materials such as dissolved metals, hydrocarbons, and nutrients in polluted runoff.

The StormFilter system comes in a variety of configurations and sizes to meet any site need. A variety of filter media is available and can be customized for each site to remove the desired pollutants.

## Basic Design

The StormFilter is sized to treat the peak flow of a water quality design storm. The peak flow or WQv is determined from

calculations based on the contributing watershed hydrology and from a design storm magnitude set by the local stormwater management agency. The StormFilter system is modular and each unit is designed with the number of cartridges required to meet the peak design flow rate, WQv or cap.

The flow rate through each filter cartridge is set to meet the jurisdictional performance requirements, allowing control over the amount of contact time between the influent and the filter media. The maximum flow rate through each cartridge can be adjusted, between 0.26 gpm/ft<sup>2</sup> and 2 gpm/ft<sup>2</sup> of surface area, using a calibrated restrictor disc at the base of each filter cartridge. Adjustments to the cartridge flow rate will affect the number of cartridges required to treat the peak flow or WQv.

Please contact your local CONTECH representative for site-specific design assistance.

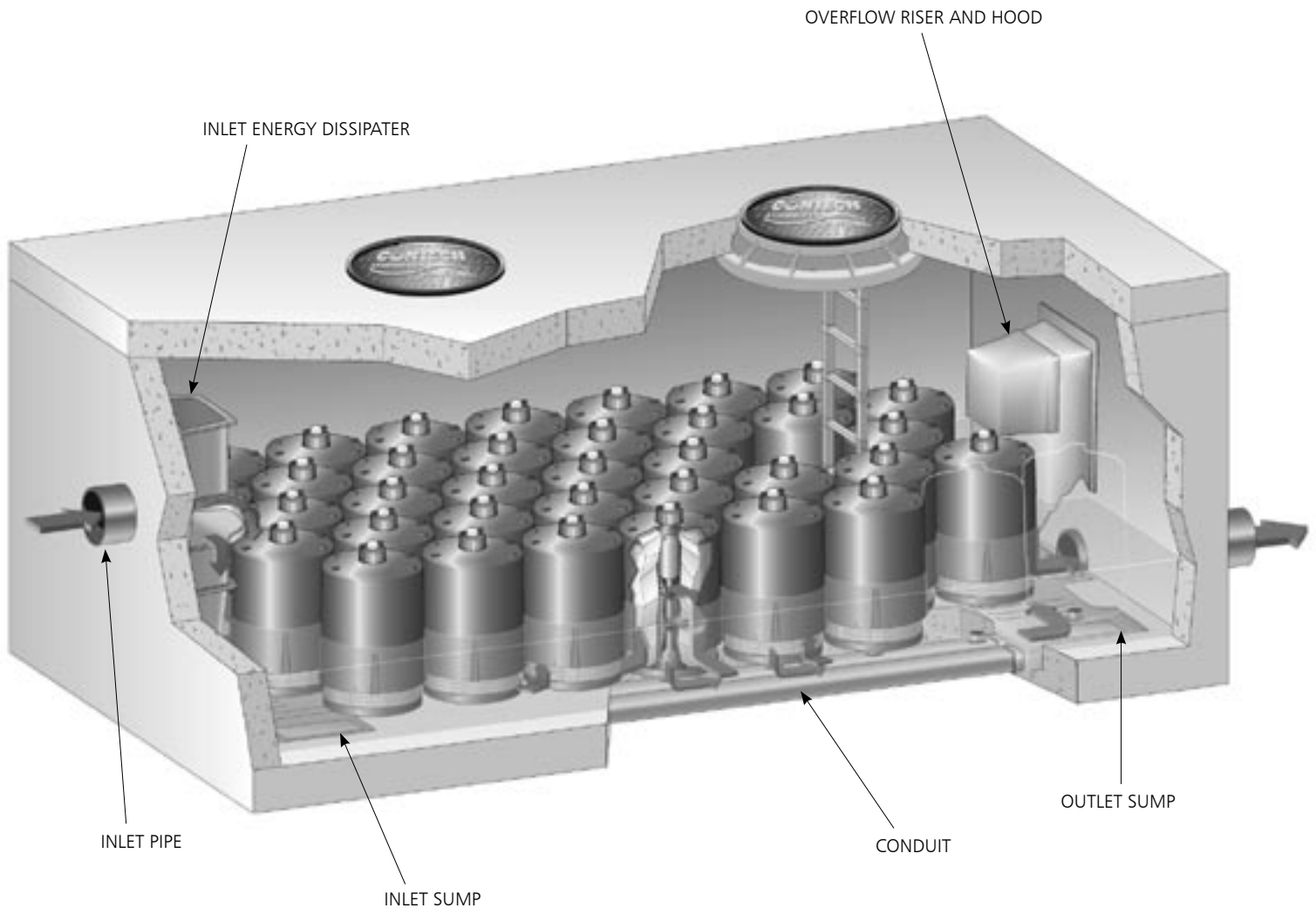

## Basic Operation

### Priming System Function

The system is designed to siphon stormwater runoff through the StormFilter cartridge. Stormwater enters a StormFilter cartridge, percolates horizontally through the cartridge's filter media and collects in the center tube where the float valve is in a closed (downward) position.

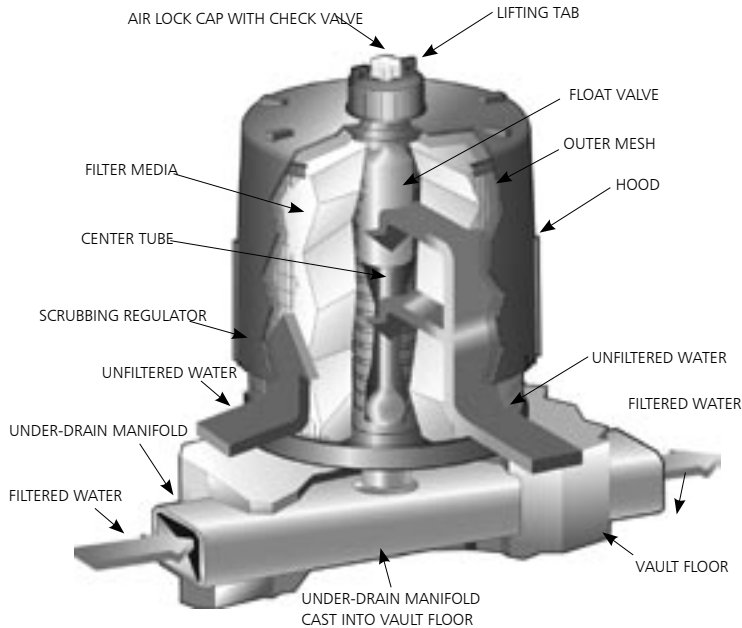

As water passes through the filter media and into the cartridge's center tube, the air in the cartridge is displaced by the water and purged from beneath the filter hood through the one-way check valve located in the cap. Once the center tube is filled with water, there is enough buoyant force to open the float valve and allow the treated water in the center tube to flow into the under-drain manifold. This causes the check valve to close, initiating a siphon that draws polluted water throughout the full surface area and volume of the filter. Thus, the entire filter cartridge is used to filter water throughout the duration of the storm, regardless of the water surface elevation in the unit. This siphon continues until the water surface elevation drops to the elevation of the hood's scrubbing regulators, and the float returns to a closed position. Utilizing the hydraulic potential in the cartridge, the scrubbing regulators cause the filter surface to be clean of attached sediments thus extending the filter's operational life.

### Flow and Valve Control

The filtration rate through a typical StormFilter cartridge can be adjusted so that it has a maximum flow rate of 2 gpm/ft<sup>2</sup> at the design driving head. The flow rate is individually controlled for each cartridge by a restrictor disc located at the connection point between the cartridge and the under-drain manifold. Consisting of a simple orifice disc of a specific diameter, the flow rate through the cartridges can be adjusted to a level that coincides with your treatment requirements by using a disc with the appropriate orifice diameter.

A reduction in flow rate affects the performance of the StormFilter system with regards to both sediment and soluble pollutants. For solids, Stokes' Law predicts the movement of sediment in a fluid and it has been proven that a reduction in the flow velocity through the system will facilitate increased settling and capture of sediments. In addition, some media types have the ability to remove soluble pollutants through chemical processes, like ion exchange. A reduction in the flow velocity through the StormFilter cartridge will increase the contact time between the stormwater and the media, thereby increasing the removal efficiency by increasing the time for a chemical process to take place.

Media type can be changed, but flow rate adjustment requires engineering consultation to ensure hydraulic demands are satisfied.

Through routine maintenance, a media filtration system can adjust the media type to target or update the system to treating specific pollutants, new TMDLs, or changing pollutants of concern. The media change out can provide a long-term solution to changing regulatory requirements.

## StormFilter Cartridges

There are three cartridge heights available for StormFilter systems: 27", 18", and Low Drop. The most economical is the 27" tall cartridge. It can treat the highest flow rate per cartridge, which creates the smallest system with the lowest installed cost. The 27" cartridge requires 3.05' of driving head to operate. For sites with less driving head available, the 18" cartridge is the next best option. Lower flow rates per cartridge increase the footprint of the overall system but only 2.3' of driving head is required. For sites with very limited drop, the Low Drop cartridge only requires 1.8" of driving head.

Cartridge Flow Rates

Cartridge Type	Hydraulic Drop	Treatment Capacity (gpm)	
		1 gpm/ft <sup>2</sup>	2 gpm/ft <sup>2</sup>
StormFilter 27"	3.05'	11.25	22.5
StormFilter 18"	2.30'	7.5	15
StormFilter Low Drop	1.80'	5	10

## StormFilter Configurations

The StormFilter is offered in seven configurations: Precast, CatchBasin, Linear, Curb Inlet, High Flow, Volume, and Dry Well.

### Precast StormFilter

The Precast StormFilter consists of one or more precast concrete structures ranging from 48" manholes to 8' x 24' vaults. The largest unit treats water quality design flows up to 3.75 cfs, and can be placed in series or in parallel to treat higher flows if needed.

A Precast StormFilter configuration can be installed online or offline from storm system, where the unit has internal overflow bypass. These systems can also be installed offline, where high flows are bypassed around the treatment system and there is no internal overflow. However, if detention, pretreatment, or bypassing is required, it can be installed offline of the storm system.

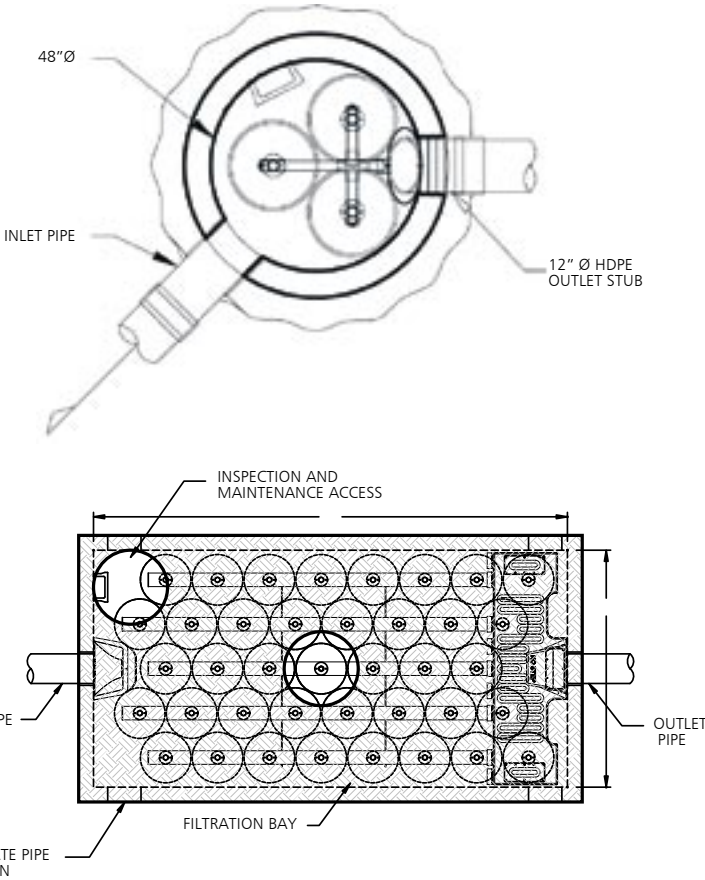

## Basic Operation

Precast StormFilter systems are housed in either a vault or manhole. Stormwater first enters the structure through the inlet pipe where it is directed through the energy dissipator. This gently spreads the flow to minimize re-suspension of previously captured pollutants.

Once in the filtration area, the stormwater begins to pond and percolate horizontally through the media contained in the filter cartridges. After passing through the media, treated water that has collected in the cartridge center tube is directed into the outlet sump by an under-drain manifold. The treated water in the outlet sump is then discharged through the outlet pipe.

Precast StormFilter systems have an internal bypass capability from 1.0 cfs to 2.0 cfs, depending upon the size of the system. If peak flows to the system exceed 2.0 cfs, an offline high flow bypass is needed.

## CatchBasin StormFilter

The CatchBasin StormFilter (CBSF) consists of a multi-chamber steel, concrete, or plastic catch basin unit that contains up to four StormFilter cartridges. The steel CBSF is offered both as a standard and as a deep unit.

The CBSF is installed flush with the finished grade and is applicable for small drainage areas from roadways and parking lots, and retrofit applications. It can also be fitted with an inlet pipe for roof leaders or similar applications.

The CBSF unit treats water quality design flows up to 0.20 cfs, coupled with an internal weir overflow capacity of 1.0 cfs for the standard steel and concrete units and 1.8 cfs for the deep steel units. Non-traffic rated plastic CBSF units have an internal weir overflow capacity of 0.5 cfs.

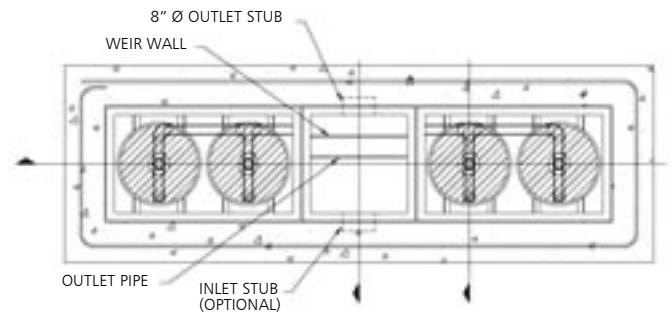

## Basic Operation

The CBSF acts as the primary receiver of runoff, similar to a standard, grated catch basin. The steel and concrete CBSF units each have an H-20 rated, traffic-bearing lid that allows the filter to be installed in parking lots and take up no land area. Plastic CBSF units can be used in landscaped areas and for other non-traffic bearing applications.

The CBSF consists of a sumped inlet chamber and cartridge chamber(s). Runoff enters the sumped inlet chamber either by sheet flow from a paved surface or from an inlet pipe discharging directly to the unit. The inlet chamber's internal baffle traps debris and floating oil, and houses an overflow weir. Heavier solids settle into the deep sump, while lighter solids and soluble pollutants are directed under the baffle and into the cartridge chamber through a port between the baffle and the overflow weir. Once in the cartridge chamber, polluted water ponds and percolates horizontally through the media in the filter cartridges. Treated water collects in the cartridge's center tube from where it is directed by an under-drain manifold to the outlet pipe on the downstream side of the overflow weir and discharged.

When flows into the CBSF exceed the water quality design value, excess water spills over the overflow weir, bypassing the cartridge bay, and discharges to the outlet pipe.

The CBSF is particularly useful where small flows are being treated or for sites that are flat and have little available hydraulic head to spare. The unit is ideal for applications in which standard catch basins are to be used. Both water quality and catchment issues can be resolved with the use of the CBSF.

## Linear StormFilter

The Linear StormFilter consists of one or two precast concrete channels that are 10' or 20' in length and 2' 9" in width.

The Linear StormFilter is installed flush with the finished grade, functioning similar to a catch basin or trench drain. The top of the unit has either covers or doors for easy access. The Linear StormFilter is typically installed online like the precast StormFilter.

The Linear StormFilter unit treats water quality design flows up to 0.27 cfs.

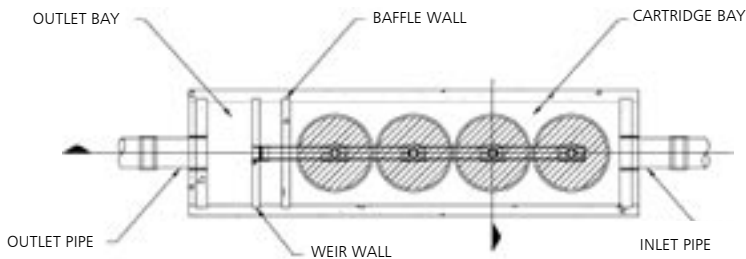

### Basic Operation

The Linear StormFilter can be installed either as the primary receiver of runoff, similar to a grated catch basin, or with an inlet stub and doors to receive runoff collected upstream.

The system is equipped with an internal overflow weir to ensure that there is no local flooding for storm events in excess of the design treatment flow. Maintenance costs for the unit are typically less because there are no confined space entry requirements, and access is quick and easy.

The Linear StormFilter is particularly useful where small flows are being treated or where the site is very flat and there is little available hydraulic head to spare.

### Curb Inlet StormFilter

The Curb Inlet StormFilter consists of a precast concrete vault ranging from 6'x8' to 8'x16' in size. These units treat peak water quality design flows up to 1.05 cfs. The system is installed online and includes an internal offline overflow bypass around the filtration chamber. The internal bypass

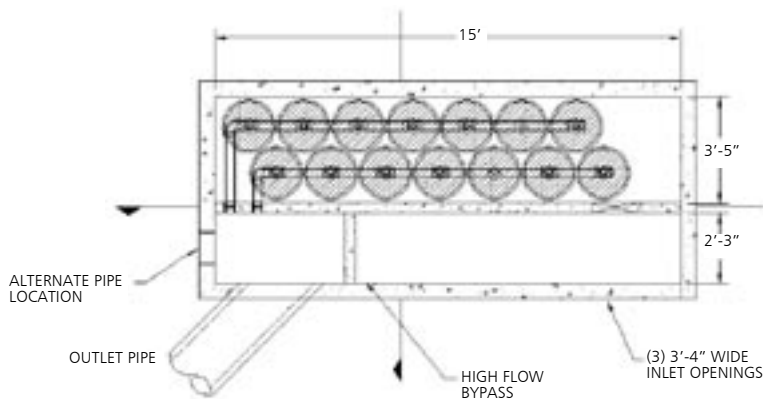

capability is based on depth of the structure. The standard bypass capacity is 15 cfs but is larger for deeper units. A traffic-bearing lid is placed underneath the median or sidewalk adjacent to the roadway.

### Basic Operation

The Curb Inlet StormFilter is composed of three bays: the inlet bay, the filtration bay, and the outlet bay. Stormwater enters the inlet bay through the curb inlet opening. The design flow is directed through a transfer opening to the filtration bay for full treatment.

Once in the filtration bay, the stormwater percolates horizontally through the media in the filter cartridges to the center tube. Treated water in the cartridge center tube is directed into the outlet bay by an under-drain manifold and discharged through the outlet pipe. Outlet pipes can be placed parallel, perpendicular, or up to 45° to the roadway. Overflow is directed over a weir wall between the inlet bay and the outlet bay, bypassing the filtration bay leaving accumulated pollutants undisturbed.

### Curb Inlet Openings

Every Curb Inlet StormFilter is designed to meet local regulations governing the geometry of the curb inlet. This can be accomplished in two ways. One way is with an integrated face plate – the vault lid includes the face plate which is tied into the curb. Another way is with a cast-in-place face plate – the entire face plate is constructed by the contractor pouring the curb. Curb inlet openings can be 4', 7', or 10' in length.

### High Flow StormFilter

High Flow StormFilter systems can be designed within a variety of structures to meet local requirements and streamline installation. These systems are designed for large sites and large flows. Too big for standard precast structures, they are usually built from precast components that are assembled on site. The High Flow StormFilter is available in several configurations: CON/SPAN®, Panel Vaults, Box Culverts, or Cast-In-Place.

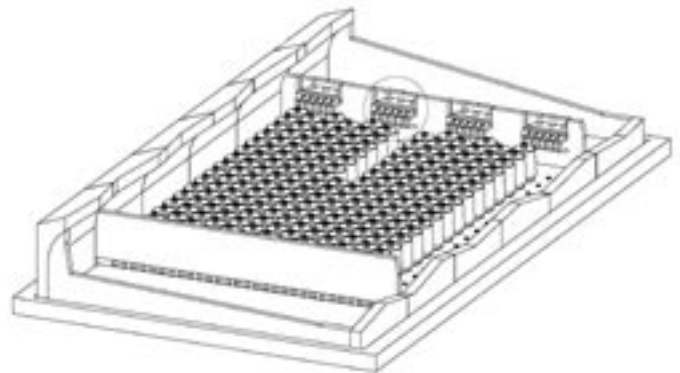

## Basic Operation

The High Flow StormFilter design has the same basic configuration and components as the Precast StormFilter but operates on a larger scale.

## Volume StormFilter

The Volume StormFilter is designed to meet volume-based regulations where a specific water quality volume (WQv) must be captured and treated. In addition to treatment, the structure can be sized to capture all or a portion of the WQv.

Restrictor discs inside each cartridge can be used to control the discharge rate from the system. The size of the disc is calibrated to provide the design filtration rate at a live storage depth. Because of these discs (and the airlock cap with a one way vent) water can be impounded above the cartridges in the treatment bay.

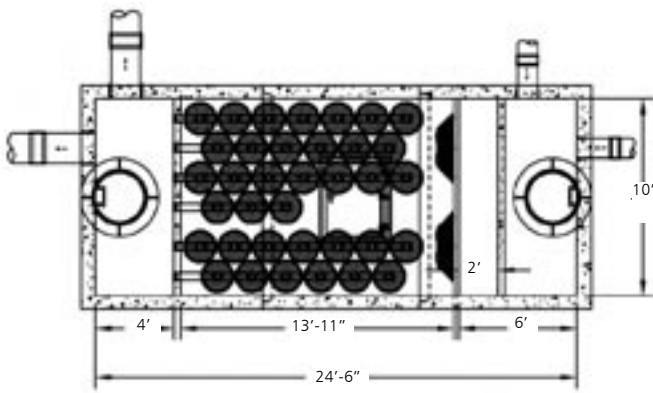

Structures range in size from a 48" manhole to CON/SPAN sections with a 24' x 10' cross section built to length. In many cases smaller structures are combined with outboard storage, such as pipe, to provide the WQv storage.

The Volume StormFilter can be designed with or without an internal bypass. If peak flows to the system exceed the internal bypass, or external bypass is required, a high flow bypass is needed. The system can also be installed online or offline and uses a traffic-bearing lid.

## Basic Operation

The Volume StormFilter is typically configured in one of two ways.

A three bay system that incorporates internal storage for the WQv and includes: the storage bay, the filtration bay, and the outlet bay. Water first enters the storage bay (a portion of which includes dead storage) which facilitates pretreatment (gravity separation) and storage of the WQv. The stormwater is then directed into the filtration bay for full treatment and additional storage. The storage bay can be designed with a baffle to trap floatables, oils, and surface scum. Cartridges in the filtration bay treat the stormwater and control the discharge rate. Once in the filtration bay, the stormwater

percolates horizontally through the media contained in the filter cartridges. After passing through the cartridge, treated water is directed to the outlet bay by an under-drain manifold where it is discharged through an outlet pipe.

A two bay, precast vault based system similar to the Vault StormFilter where pretreatment and live storage are provided upstream.

Providing WQv storage in an outboard storage facility such as storage pipe provides the versatility to meet most footprint and elevation requirements.

## Dry Well StormFilter

The Dry Well StormFilter provides treatment, infiltration and groundwater protection in a single structure. The system is designed to treat conveyed flow or sheet flow from small drainages. Multiple units can be installed to treat any size site. Because it provides treatment and infiltration in a single unit, the total number of structures and the amount of pipe required for the stormwater system are reduced.

The Dry Well StormFilter system is available in 48", 60" and 72-" pre-cast manhole top sections that are designed to be stacked on top of dry well infiltration risers. The StormFilter portion of the unit arrives fully assembled and ready to install, including an integrated concrete deck for the StormFilter cartridges. The system can also be retrofitted into existing 48" manhole dry wells.

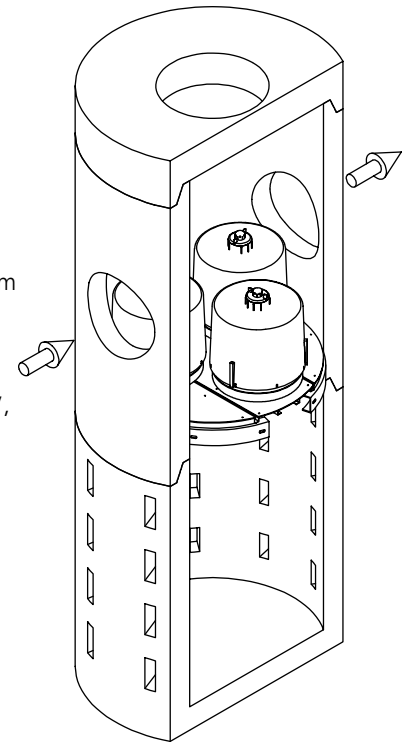

## Basic Operation

Stormwater enters the dry well unit through one or more entry pipes or channels at its top. It then percolates through the media in the StormFilter cartridge to the center tube. Treated water in the cartridge center tube is discharged to the infiltration section below, and then infiltrates into the surrounding soils through a number of small exit openings at the sides and bottom.

## StormFilter Media

The removal of site-specific pollutants can be maximized with the variety of filtration media available. In many cases, different media types can be combined so as to target a wide spectrum of pollutants. This ability to combine and use various media types allows the system to be easily adjusted to meet ever-changing site conditions and increasingly stringent regulatory requirements.

### Perlite

Perlite is a natural, volcanic ash, similar in composition to glass and similar in appearance to pumice. To use perlite as a filter medium, it must first go through a heating process to yield a lightweight, multicellular, expanded form. This expanded form has a coarse texture, very low-density, high surface area, and stable, inert chemistry, all of which make perlite an excellent physical filtration medium.

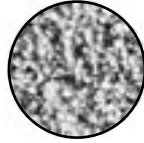

Perlite has proven to be our media of choice for sediment and oil removal. The multicellular nature of expanded perlite is the key to its excellent ability to trap sediments and adsorb oil. The coarse texture of the expanded perlite creates a bed of material with a very high porosity, which allows perlite to have the highest sediment and oil storage capacity of all of the available media options.

### Zeolite

The term zeolite defines a family of both natural and synthetic, hydrous aluminosilicate materials with a highly porous mineral matrix that holds light, alkali metal cations (ideally sodium ions).

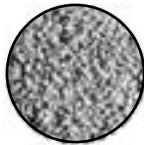

Zeolite has the ability to use a cation exchange reaction that removes other cations such as zinc, copper, lead, and ammonia from water. In the cation exchange reaction, the light metal cations in the zeolite matrix are displaced by the heavier metal cations, such as copper, in the water.

The zeolite used in our system is clinoptilolite, which has a cation exchange capacity (CEC) of approximately 100 to 220 meq/100 g. Clinoptilolite has inert characteristics that make it an excellent metals removal media option when CSF media cannot be used. It can be combined with other media such as GAC and perlite when metals are not of exclusive concern.

### CSF® Leaf Media

CSF Leaf Media is a patented filtration media composed of composted deciduous leaves originating from the City of Portland, Oregon. CONTECH Stormwater Solutions purchases the mature, stable, deciduous leaf compost and then processes it into an odorless, pelletized compost product with physical and chemical characteristics desirable for stormwater filtration.



The patented compost process creates a material with excellent flow-through characteristics and stability in water. Not only do

CSF Leaf Media consist of 100% recycled, all natural materials, but it also provides good removal of sediments and excellent removal of a wide range of toxic contaminants.

CSF Leaf Media provides the multitude of beneficial water treatment properties typical of soil in a form that is compatible with the compact, modular, media-based design of the StormFilter system. In addition to the physical filtration provided by the granular nature of the CSF Leaf Media, the complex chemistry of the compost also provides chemical filtration as well.

Sediment and total nutrients are removed through physical filtration. Oil, complexed metals, and anthropogenic organic contaminants such as herbicides and pesticides are removed through adsorption, the physical partitioning of organic compounds, such as pesticides, to carbon-rich materials, such as the compost.

Soluble metals are removed by cation exchange, as well as by complexation of metal ions to the organic chelating agents present in compost. CSF Leaf Media is an excellent, cost-effective, all-purpose media that epitomizes the potential value of recycled materials.

### GAC

GAC (Granular Activated Carbon) is a widely accepted water filtration media used for the removal of organic compounds. It consists of pure carbon (originating from coal or charcoal) whose micro-porous structure has been enhanced through steam or acid "activation."

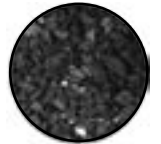

The high carbon content and porous nature of GAC accounts for its excellent ability to remove organic compounds through adsorption. Since adsorption is the physical partitioning of organic compounds to high carbon surfaces, the "activation" of the carbon (which creates GAC) endows it with an enormous surface area upon which adsorption can take place.

In situations where anthropogenic organic contaminants are of exclusive concern, GAC media provide the highest level of stormwater treatment compared to other available media options. However, because it is not very often the case that anthropogenic organic contaminants are of exclusive concern, GAC is usually combined with another media such as perlite or zeolite for the treatment of additional contaminants.

Combination of GAC with perlite constitutes the most cost-effective configuration, as the effectiveness of GAC is drastically reduced if it is coated with high concentrations of heavy oil or sediment, which can restrict access via surface pores to the interior of the GAC granules.

### ZPG™ (Zeolite, Perlite, GAC blend)

This proprietary blend of zeolite, perlite, and granular activated carbon media is used to provide an alternative for CSF media for installations where leaf media cannot be used.



## Laboratory and Field Testing

The StormFilter system is designed to meet the most stringent regulatory requirements. The field-proven performance of the StormFilter has led to hundreds of regulatory agency approvals nationwide as a standalone BMP.

The Stormwater Management StormFilter® is the first manufactured BMP to receive stand-alone approval through field testing and satisfying the total suspended solids treatment requirements in Washington and New Jersey.

Log on to [www.contechstormwater.com/stormfilter](http://www.contechstormwater.com/stormfilter) to view the following reports in full.

## Field Monitoring Reports

Field Proven Performance of the StormFilter using the Technology Assessment Protocol - Ecology (TAPE) and Technology Acceptance Reciprocity Partnership (TARP) Tier II Protocol

1. Washington
  - a. Washington State Department of Ecology General Use Level Designation for Basic Treatment
  - b. Technical Evaluator Engineering Report (TEER). Gary Minton, Ph.D., P.E.
2. New Jersey
  - a. New Jersey State Department of Environmental Protection Final Certification
  - b. New Jersey Corporation for Advanced Technology (NJCAT) Field Verification Report

## Laboratory Reports

### ***Total Suspended Solids (TSS) Removal Using Different Particle Size Distributions with the Stormwater Management StormFilter.***

#### ***Influences on TSS removal efficiency***

Influence of analytical method, data summarization method, and particle size on total suspended solids (TSS) removal efficiency of the StormFilter

#### ***StormFilter removal efficiency with coarse/fine perlite media***

Evaluation of the removal of silt loam TSS using coarse/fine perlite at 28 L/min (7.5 gpm).

#### ***StormFilter removal efficiency with ZPG media***

Evaluation of the removal of SIL-CO-SIL 106 using ZPG media at 28 L/min (7.5 gpm)

#### ***StormFilter removal efficiency with coarse perlite***

Evaluation of the removal of sandy loam TSS using coarse perlite at 57 L/min (15 gpm)



800.925.5240  
[contechstormwater.com](http://contechstormwater.com)

## Support

- Drawings and specifications are available at [contechstormwater.com](http://contechstormwater.com).
- Site-specific design support is available from CONTECH Stormwater Design Engineers.

©2007 CONTECH Stormwater Solutions

CONTECH Construction Products Inc. provides site solutions for the civil engineering industry. CONTECH's portfolio includes bridges, drainage, sanitary sewer, stormwater and earth stabilization products. For information on other CONTECH division offerings, visit [contech-cpi.com](http://contech-cpi.com) or call 800.338.1122

Nothing in this catalog should be construed as an expressed warranty or an implied warranty of merchantability or fitness for any particular purpose. See the CONTECH standard quotation or acknowledgement for applicable warranties and other terms and conditions of sale.